



Solutions for Daily Living

COLUMBIA MEDICAL MFG. LLC warrants this product to be free of defects in material and workmanship. Our obligation under this warranty is limited to repair or replacement of any part or entire unit at our option for a period of one year from date of delivery to the original purchaser. The warranty does not include cost of inconvenience, property damage, misuse, abuse, accident or similar incidents. The warranty will not apply if product has been tampered with or repaired by unauthorized individuals.

13577 Larwin Circle
Santa Fe Springs, CA 90670
(310) 454-6612 (800) 454-6612
Fax: (310) 305-1718
Email: info@columbiamedical.com
Website: www.columbiamedical.com



Solutions for Daily Living



Model #2500

Model #2000

Therapedic™ Positioning Restraint System Model #2000 and Model 2500

Instructions for Use

MODEL #2000: Use only with individuals who weigh between 20 and 102 pounds (9.1 - 46.3 kg) and whose height is less than 60 inches (<152.4 cm).

MODEL #2500: Use only with individuals who weigh between 40 and 130 pounds (18.1 - 59.0 kg) and whose height is 54 – 66 inches (137.2 – 167.6 cm).

Table of Contents

Important Safety Information	Page 3
Vehicle Seat Belt Compatibility	Page 6
Vehicle Seat Positions	Page 7
Therapedic™ Features	Page 8
Installation Instructions	Page 10
Lap and Shoulder Belt (Recommended)	Page 10
Lap and Shoulder Belt—Requires Locking Clip	Page 11
Lap Belt Only	Page 13
Installing the Tether Strap	Page 15
Latch Vehicle Installation.....	Page 16
Non-Latch Vehicle Installation.....	Page 18
Components and Adjustments	Page 19
Operating the Harness Buckle.....	Page 19
Checking the Harness Height	Page 20
Adjusting the Harness Height	Page 20
Adjusting the Harness Fit	Page 20
Adjusting the Chest Clip	Page 21
Adjusting the Head Pads	Page 21
Adjusting Lateral Positioning Pads.....	Page 21
Optional Accessories	Page 22
Seat Depth Extender.....	Page 22
Extensor Thrust Wedge.....	Page 22
Swing-Away Abductor	Page 22
ShurShape™ Custom Inserts	Page 23
Block Style Positioning Pads.....	Page 23
BuckleGuard.....	Page 23
Therapedic Explorer Mobility Base.....	Page 23
Securing the User in the Restraint	Page 24
Care and Maintenance	Page 25
Removing the Cover	Page 25
Refitting the Cover.....	Page 25
Cleaning the Fabric.....	Page 25
Cleaning the Harness and Buckle	Page 26
Copy of Registration Card	Page 27

Copy of Registration Card

FOR YOUR CHILD'S CONTINUED SAFETY

Please *promptly* fill out and *return* the attached card.

Although child restraint systems undergo testing and evaluation, it is possible that a child restraint could be recalled.

In case of recall, we can reach you only if we have your name and address, so send in the attached card to be on our recall list.

In order to properly register your child restraint system, you will need to provide the model number, serial number and date of manufacture. This information is provided on the attached card.

Please fill out and mail this card NOW!

The card is already addressed and the postage is paid.

Therapedic™ Registration Card

Tear off and mail this part.

Please fill in your name and address.

Name: _____

Address: _____

City: _____ State: _____ Zip: _____

Email: *(optional)* _____



Solutions for Daily Living

Therapedic™ Positioning Restraint System

Date of Manufacture: ____/____/____

Manufactured in Santa Fe Springs, CA USA

Sticker with model name,
model number and serial
number.

Cleaning the Harness and Buckle

- The harness straps may be cleaned by sponging them with warm water and a mild detergent.
- The buckle may be cleaned with a damp cloth and mild detergent.
- Towel dry — make sure the that harness and buckle are completely dry before reinstalling.
- DO NOT bleach, machine wash or machine dry.
- DO NOT disassemble the harness.
- DO NOT use abrasive cleaners.

Please complete and return the owner registration card within 30 days of purchase. This registration card is attached to the shoulder strap of the Positioning Restraint System. A sample of the registration card is shown below.

IMPORTANT

In case of a recall, we can reach you only if we have your name and address. You MUST send in the attached card to be on our recall list.

The postage is paid.

Do it today!



WARNING! DEATH OR SERIOUS INJURY can occur:

MODEL #2000: Use only with individuals who weigh between 20 and 102 pounds (9.1— 46.3 kg) and whose height is less than 60 inches (<152.4 cm).

MODEL #2500: Use only with individuals who weigh between 40 and 130 pounds (18.1 — 59.0 kg) and whose height is 54 – 66 inches (137.2 – 167.6 cm).

- Snugly adjust the belts provided with this Positioning Restraint System around the user. A snug strap should not allow any slack. It lies in a relatively straight line without sagging. It does not press on the user's flesh or push the user's body into an unnatural position.
- Secure the top anchorage strap (tether) provided with this Positioning Restraint System.
- Secure this Positioning Restraint System with your vehicle's seat belt.
- **Read and follow all instructions** on this Positioning Restraint System and in the written instructions located on the side of the restraint.
- **Register your Positioning Restraint System** by completing and sending in the registration card. Although restraint systems undergo testing and evaluation, it is possible that a restraint could be recalled for safety reasons. You must register this restraint to be reached in the case of recall. Send your name, address, email (optional), and the restraint's model and serial number and manufacturing date to Columbia Medical, 13577 Larwin Circle, Santa Fe Springs, CA 90670 USA or call 800-454-6612. For recall information, call the U.S. Government's Vehicle Safety Hotline at 1-888-327-4236 (TTY: 1-800-424-9153), or go to <http://www.NHTSA.gov>.

- This Positioning Restraint System is designed to fit a wide range of individuals. To ensure a proper fit for the user, it is important that the restraint be correctly set up and installed before using it for the first time.
- Use this Positioning Restraint System in the forward-facing position only. This restraint is not designed for use in a rear-facing position. The American Academy of Pediatrics recommends forward facing only after one year old.
- Do not use this Positioning Restraint System with your vehicle's lower anchor LATCH connector system. Use only the vehicle's seat belts for installation. Upper LATCH anchor points are used to secure the tether.
- **Do not use this Positioning Restraint System in the front seat of a vehicle with a passenger air bag unless the air bag is turned off. DEATH or SERIOUS INJURY can occur.** According to accident statistics, individuals are safer when properly restrained in the rear seating position than in the front seating position. Regardless of seating position, the Federal government recommends that all children under twelve years of age ride in the rear seat.
- When using this Positioning Restraint System in a vehicle with side air bags, refer to the vehicle owner's manual for child restraint installation instructions and precautions.
- Do not use this Positioning Restraint System with vehicle seats that face to the side or rear or with vehicle seats with backs that can fold forward in a crash or sudden stop. Check your owner's manual or with your dealer if you are not sure.
- Read the section on **vehicle seat belt compatibility** to determine the type of seat belts that may be used with this Positioning Restraint System.
- Do not route the vehicle seat belt over the user while using this Positioning Restraint System.

Cleaning Instructions

Removing the Cover

- Remove the head pads and positioning pads (if present) by releasing the lanyards from the back of the restraint system.
- Remove the foam blocks from the head pads.
- Remove the head pad lanyard, by pressing the button on the plastic ball on the inside of the restraint and removing it from the lanyard. Then remove the lanyard from the outside of the restraint shell.
- Remove the harness completely by locating the metal bracket securing the top of the harness along the back side of the restraint. Pull it away to expose 3"- 4" of webbing. Turn the metal bracket so the short side will fit through the slot in the back of the restraint and push it through the slot and the cover.
- Repeat procedure above for the two shoulder straps and two lap straps.
- Remove the cover by lifting the edges of the cover over the shell of the restraint.

Refitting the Cover

- The cover, harness and pads can be reinstalled by following the instructions above in reverse order.

Cleaning the Fabric

- The cover, head pad covers, positioning pad covers (if present) and shoulder pads may be washed. It is recommended that you do not wash these items with other items.
- Hand wash or machine wash on the "gentle" cycle with a mild detergent. Water temperature should be "cold".
- Do not use bleach.
- Machine dry using the lowest-heat cycle (e.g. "fluff"). Make sure all fabric components are dry before reinstalling them on the restraint.
- Do not iron.

Securing the User in the Restraint

Once the Therapedic™ Positioning Restraint System has been properly fitted and installed in the vehicle, follow these instructions to secure the user in the restraint.

1. Open the harness and move the harness straps to the side of

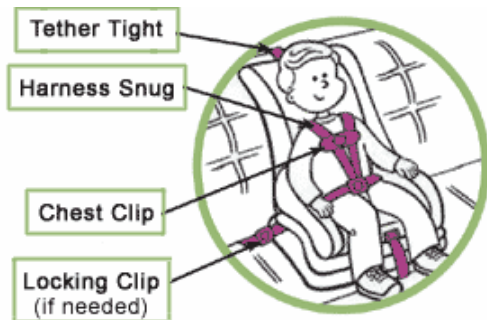

the restraint.

2. Place the user in the restraint with his/her back positioned against the back rest in as upright a position as possible.
3. Verify that the harness straps are located in the slots above, but closest to the top of the user's shoulders.
4. If the harness straps are not in the appropriate position, move them according to the instructions provided in **Adjusting the Harness Height**.
5. Place the harness shoulder straps over each of the user's shoulders making sure that the straps are not twisted or binding on any object.
6. Fasten the metal latch on each shoulder strap securely into the buckle.
7. Fasten the plastic chest clip and position it in the middle of the users chest — aligned with the armpits of the user.
8. Check to ensure the harness fit is snug. If needed, adjust the harness fit as noted in **Adjusting the Harness Fit**.
9. To remove the user, reverse steps outlined above.

- The harness assembly is for use only with the Therapedic Positioning Restraint System. Do not use the harness independently of the seat.
- To maintain its safety, if your Positioning Restraint System becomes badly worn or damaged, or is involved in an accident, regardless of speed and regardless how minor, your restraint system may no longer be effective and should immediately be replaced.
- Secure this Positioning Restraint System even when it is not occupied; in a crash, an unsecured restraint may injure vehicle occupants.
- Metal parts on a restraint system can become hot inside a closed automobile in the sun. Always check that the metal parts are not too hot before putting the occupant in the seat. If you park in the sun, covering your seat with a blanket or towel will help keep the metal parts from heating up.
- Never leave children unattended in the vehicle, even if they are secured in a restraint system. Children could be seriously or fatally injured through excessive exposure to extreme heat or cold.
- Do not leave loose objects in the passenger compartment of your vehicle. In the event of an accident, these objects can become projectiles and cause serious injury or death.

IMPORTANT SAFETY INFORMATION:

MODEL #2000: This restraint system conforms to all applicable Federal motor vehicle safety standards. **This restraint is certified for use in motor vehicles and aircraft.**

MODEL #2500: This restraint system conforms to all applicable Federal motor vehicle safety standards. **This restraint is certified for use in motor vehicles. It is not certified for use in aircraft.**

Vehicle Seat Belt Compatibility

IMPORTANT: Vehicle seats and safety seat belts differ from vehicle to vehicle. Always refer to your vehicle owner's manual or call the vehicle manufacturer for specific information about the use of child restraint systems in your vehicle. Some vehicles may have seating positions or seat belts which are not compatible with this Positioning Restraint System, or any other restraint system.

VEHICLE SEAT BELTS THAT CAN BE USED:

- **Continuous-loop lap-shoulder belts with a sliding latch plate.** This type of seat belt consists of continuous webbing that is bolted to the vehicle on one end and has a retractor on the other end. The latch plate (the "male" part of the seat belt buckle) slides freely along the webbing to form a lap belt and a shoulder belt when attached to the buckle.
- **Combination lap-shoulder belts with a locking latch plate.** This type of seat belt has a latch plate (the "male" part of the seat belt buckle) that locks into place for securing the restraint system.
- **Lap belts with automatic locking retractors.** These lap belts automatically lock to whatever length they have been pulled to, after which they can only be reset by retracting the belt completely.
- **Lap belts with a locking latch plate.** This type of seat belt stays locked after the seat belt is tightened by pulling the free end.

VEHICLE SEAT BELTS THAT CANNOT BE USED:

- Seat belts with the top and/or bottom anchor attached to the vehicle door.

Shurshape™ Custom Inserts

A unique way to provide custom molded seating. The inserts are molded and retain a custom fit shape.



Block Style Positioning Pads

Additional pads for special positioning needs. Block style, two pads 2½" thick and two pads 1½" thick.



BuckleGuard

Prevents a child from releasing the shoulder harness.

Therapedic™ Explorer Mobility Base

Lightweight, folding frames. Ideal alternatives to traditional positioning wheelchairs. Perfect for use while shopping at the mall, going to the playground or traveling.



- side width of the car seat if the seat is too wide.
3. Use only as many pads as needed for a correct fit. As a guideline, you should have about one inch of space on either side of the user and the restraint seat cover.
 4. To adjust pads, lift the upholstery cover from the sides of the restraint shell. The pads are located between the inside of the plastic shell and the cover.
 5. Stretch the upholstery cover back over the pads and the edge of the shell.

Optional Accessories

Seat Depth Extender

The seat depth extender provides extra support for taller individuals. It is used when a user's legs have grown too long to allow a comfortable seating position.



Extensor Thrust Wedge

Changes seat to back angle by increasing the front height.

Swing-Away Abductor

The swing-away abductor is used to improve hip alignment and stabilize seating posture.



- Lap belts with an emergency locking retractor (ELR), which means that the lap belt will only lock in the event of a sudden stop or crash.
- Motorized seat belts that automatically surround the passenger when the door is closed.
- Combination lap and shoulder belts with a "sewn lock plate". The lap belt is sewn to the side of the lock plate (the "male" part of the seat belt buckle), while the shoulder belt is sewn to the top of the lock plate. Each belt feeds into a separate emergency-locking retractor prohibiting proper control of the seat belt tension.

Vehicle Seating Positions

- This Positioning Restraint System must **ONLY** be used in **forward-facing vehicle seats**.
- This Positioning Restraint System is to be used **ONLY** in the **forward-facing position**.
- This Positioning Restraint System **CANNOT** be used in the following seating positions:
 - ◊ Rear-facing vehicle seats, such as those in some vans or buses.
 - ◊ Side-facing vehicle seats, such as those in some vans and pick-up trucks.
 - ◊ Flip-down vehicle seats, often referred to as "jump-seats."

NOTE: According to research sponsored by the National Highway Traffic Safety Administration, children are significantly safer when properly restrained in the back seat, compared to the front seat.

Therapeutic™ Features



1. Adjustable Head Pads
2. Shoulder Harness Pads
3. Lateral Positioning Pads (under cover)
4. Crotch Strap Pad
5. Chest Clip.
6. Buckle
7. Harness Straps and Clip
8. Metal Side Tubes
9. Buckle Adjustment Strap
10. Tether Strap
11. Instructional Video
12. Locking Clip for Seat Belt

- not over the stomach area.
3. If necessary, the position of the buckle can be changed by adjusting the metal bracket on the bottom of the restraint.
4. The shoulder straps can be independently adjusted by pressing the grey button on the tension adjuster then adding or removing slack in the webbing as necessary to obtain a snug fit.
5. A snug strap should not allow any slack. It lies in a relatively straight line without sagging. It does not press on the user's flesh or push the user's body into an unnatural position.

Adjusting the Chest Clip

Important: The correct height for the chest clip is at the middle of the chest — level with the armpit.

1. The chest clip keeps the shoulder straps of the harness from sliding down off the shoulders.
2. The chest clip is fastened by fitting the two halves together. The chest clip is properly secured when a click is heard.
3. The chest clip is opened by squeezing the middle tab and pulling the two pieces apart.
4. With the harness properly attached and the chest clip fastened, the chest clip should be positioned at the middle of the chest, in line with the armpits of the user.

Adjusting the Head Pads

1. The Positioning Restraint System has adjustable head pads.
2. Determine if the head pad(s) need to be adjusted.
3. Locate the plastic ball on the lanyard that is located behind and to the side of each head pad.
4. Press the button on the plastic ball, sliding the head pad along the lanyard to the desired height, then release the button to secure the head pad into position.

Adjusting Lateral Positioning Pads

1. The Positioning Restraint System comes standard with four flat positioning pads which are designed to be adjusted to offer the user more or less support as needed. The pads are located under the cover on the sides of the restraint.
2. The lateral positioning pads can be used to decrease the in-

Checking the Harness Height

1. Place the user in the Positioning Restraint System and properly secure with the harness.
2. Note the position of the harness relative to the shoulder of the user.
 - Harness straps should be inserted in the nearest slot at or above the user's shoulder.
 - If the harness height is correct, the restraint can be used with no further adjustment.
 - If the height of the user's shoulder is above the harness it will be necessary to adjust the harness. See **Adjusting the Harness Height**.

Adjusting the Harness Height

1. To adjust the harness, it is necessary to remove the Positioning Restraint System from the vehicle.
2. Place the user in the restraint and identify the closest harness slot at or above the height of the user's shoulder.
3. Remove the user from the restraint prior to making any adjustments to the harness.
4. Locate the metal bracket securing the top of the harness along the back side of the restraint and pull it away to expose 3"- 4" of webbing.
5. Turn the metal bracket so the short side will fit through the slot in the back of the restraint and push it through the slot as well as the cover.
6. Reposition the harness to the correct slot and reverse the process to reinstall the harness.
7. After repositioning the harness, make sure the metal bracket is flat against the back of the restraint to prevent it from slipping out.



Adjusting the Harness Fit

1. With the user in the restraint, check the location of the buckle.
2. The buckle should be positioned at the level of the user's hips,

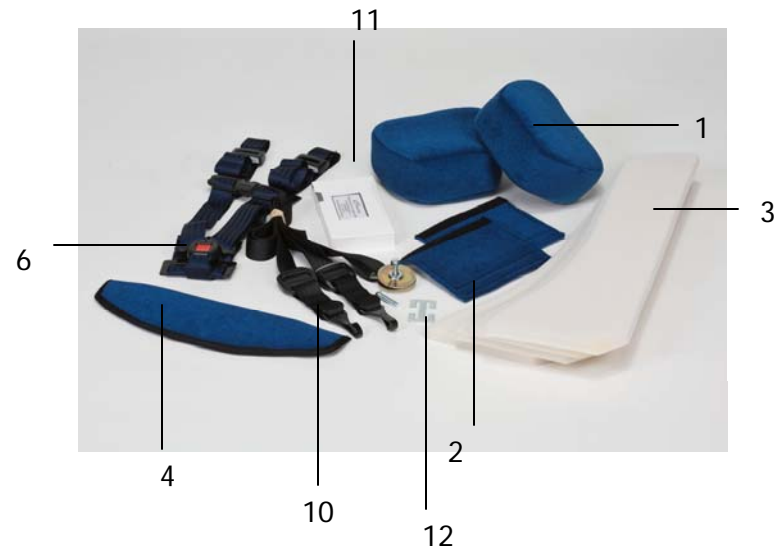

Installation

The Therapeutic Positioning Restraint System must be installed with a Tether Strap which is included. The tether strap must be attached properly to a LATCH top tether anchor or must be bolted into a structurally secure location in the vehicle. See "Installing the Tether Strap."

Use of the tether improves the safety of the Positioning Restraint System and reduces the risk of injury.

Lap and Shoulder Belt (Recommended Method)

This is the recommended method for installing the Therapeutic Positioning Restraint System and is used in vehicles equipped with an **Automatic Locking Retractor (ALR)** function. The ALR allows the user to lock the retractor at a set position (also called **child restraint mode**) used for **securing child seats**. ALR mode is activated by extending the retractor all the way out until a "click" is heard, next let the seat belt (webbing) retract into the retractor to the desired length and stop the belt at that point. The retractor locks and will not let the belt lengthen at that point (only retract).

1. Place the Positioning Restraint System in a forward facing position on the vehicle seat. **If the front edge of the restraint extends more than one inch (1") beyond the front edge of the seat, then the vehicle seat is too shallow to properly support the restraint system. If this is the case, do not install.**
2. Attach the tension adjuster hooks of the tether to the upper anchor points located on the sides of the Positioning Restraint System. See **Installing the Tether Strap**.
3. Attach the tether loosely to an approved anchor point in the vehicle. In cars built after 2002, approved anchor points can be identified by this symbol. Refer to your vehicle owner's manual if needed.
4. Verify that the seat belt in the vehicle can be used with the Positioning Restraint System. See **Vehicle Seat Belt Compatibility**.



Components and Adjustments



The Therapeutic Positioning Restraint System includes the following standard components:

- 5-Point Safety Harness
- Shoulder Harness Pads
- Adjustable Head Pads
- Crotch Strap Pad
- Lateral Positioning Pads
- Tether Strap Kit
- Locking Clip



Operating the Harness Buckle

- To release, press the red button on the harness buckle.
- To close, insert one metal latch into the harness buckle until it clicks. Repeat for the other metal latch.
- Always make sure both latches are properly fastened in the harness buckle when securing a user.
- Never lubricate the harness buckle.

- **For individuals greater than 80 lbs. (>36 kg):** use two (2) tether hooks attaching one (1) tether hook to the tether anchor immediately behind the restraint AND one (1) tether hook to the closest adjacent tether anchor. **See Figure 8.**

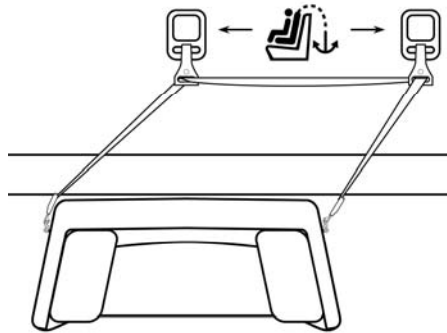
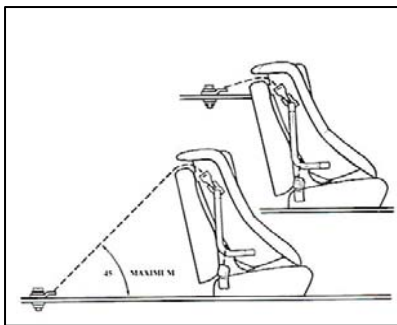

Figure 8: Double hook attachment for individuals over 80 lbs.

5. Remove any slack in the tether by pulling the loose ends of the tether through the tension adjuster hooks.



6. Verify that the tether is appropriately attached and tensioned as noted above.

Figure 9: Tether Anchoring Methods

Non-LATCH Vehicle Installation: If the desired seating position in the vehicle does not have a LATCH top tether anchor (which may be the case for vehicles that were made before 2002), it is necessary to use a bolt-in anchor mounting bracket to secure the tether strap. Contact Columbia Medical directly for more details on acquiring an anchor mounting bracket (800) 454-6612.

5. Pull the seat belt out completely to engage the retractor, then route the belt between the back of the restraint and the metal tubes which are located along the sides of the Positioning Restraint System.

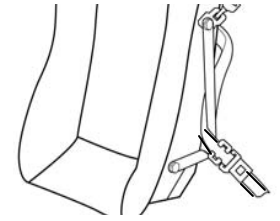

6. Make sure that the seat belt is not twisted, then buckle in place.
7. Make sure the restraint system is flat against the vehicle seat's bottom and back. Use your hands to apply firm pressure to the restraint, pushing it into the vehicle backrest—or better yet, place your knee on the restraint and push down with all your weight—while pulling on the vehicle seat belt and removing all slack from it.
8. Check to make sure the tether strap is not twisted and then tighten to secure the upper portion of the restraint. If the vehicle does not have a top tether anchor point, it will be necessary to use a bolt-in anchor mounting bracket. **See Installation Without LATCH Top Tether Anchors.**
9. **DO NOT USE** this restraint without the tether strap properly installed.
10. Verify that the vehicle seat belt is tight and that the Positioning Restraint System is secure. When properly installed, the restraint will not move more than one inch (1") from side to side and or front to back. If the restraint is not secure, repeat steps 5 – 8.

Lap and Shoulder Belt – Requires Locking Clip

This method of installation is required when installing the Therapeutic Positioning Restraint System in a vehicle with an emergency locking retractor (ELR) type of seat belt. **Emergency Locking Retractor (ELR)** function allows the occupant to have free movement while buckled up, but in the event of an emergency situation, such as heavy braking or collision, the retractor instantly locks securing the occupant. This type of seat belt is "webbing sensitive," meaning that any sudden movement of the webbing (the seat belt strap) causes the retractor to instantly lock. **A locking clip is required to achieve the proper tension when using this belt type to secure a restraint.**

1. Place the Positioning Restraint System in a forward facing position on the vehicle seat. **If the front edge of the restraint extends more than one inch (1") beyond the front edge of the seat, then the vehicle seat is too shallow to properly support the restraint system. If this is the case, do not install.**
2. Attach the tension adjuster hooks of the tether to the upper anchor points located on the sides of the Positioning Restraint System. **See Installing the Tether Strap.**
3. Attach the tether loosely to an approved anchor point in the vehicle. In cars built after 2002, approved anchor points can be identified by this symbol. Refer to your vehicle owner's manual if needed.
4. Verify that the seat belt in the vehicle can be used with the Positioning Restraint System. **See Vehicle Seat Belt Compatibility.**
5. Pull the seat belt out completely then route the belt between the back of the restraint and the metal tubes which are located along the sides of the Positioning Restraint System.
6. Make sure that the seat belt is not twisted, then buckle in place.
7. Make sure the restraint system is flat against the vehicle seat's bottom and back. Use your hands to apply firm pressure to the restraint, pushing it into the vehicle backrest—or better yet, place your knee on the restraint and push down with all your weight—while pulling on the vehicle seat belt and removing all slack from it.
8. Pinch the shoulder and lap portions of the seat belt together immediately behind the latch, then release the seat belt latch from the buckle.
9. Fold the webbing and thread it through the locking clip, one side at a time keeping the locking clip as close as possible to vehicle belt latch – no further than ½" away. **See Figure 3.**
10. Buckle the seat belt to see that the clip has been correctly installed, with all slack webbing gone and the restraint tightly in place.
11. Check to make sure the tether strap is not twisted and then tighten to secure the upper portion of the restraint. If the vehicle does not have a top tether anchor point, it will be



3. Attach one tension adjuster hook to the upper side anchor bracket located on each side of the restraint. **See Figure 6.**

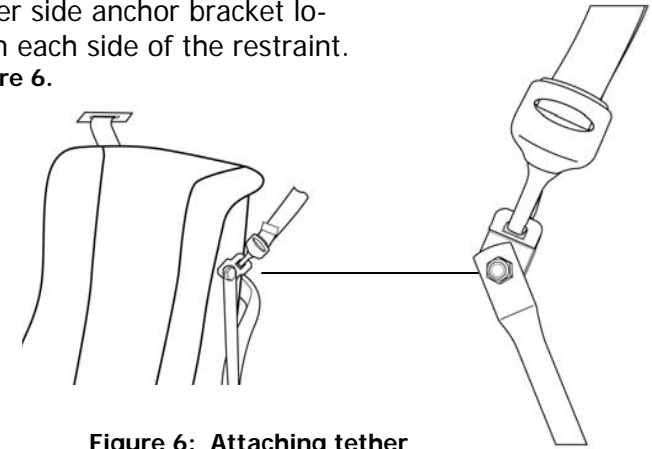

Figure 6: Attaching tether to upper side anchor

4. Attach the tether hook(s) to the vehicle's tether anchor(s). The primary tether anchor to use will be located immediately behind the restraint.
 - **For individuals less than 80 lbs. (<36 kg):** attach one (1) tether hook to the tether anchor immediately behind the restraint. **See Figure 7.**

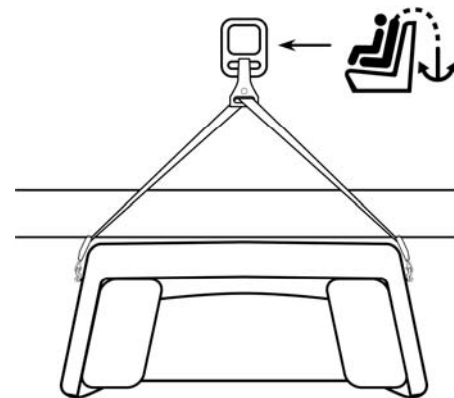

Figure 7: Single hook attachment for individuals under 80 lbs.

- An incorrectly mounted restraint system may come loose during an accident which could result in serious injury or death to the user.
- Damaged or impact damaged restraint systems must be replaced.
- **For occupants over 80 lbs. (>36 kg), BOTH tether hooks must be used. Each hook must be attached to a separate tether anchor. A single tether anchor is not strong enough to support weights in excess of 80 lbs. (>36 kg).**

Installing the Tether with LATCH

1. The tether is not attached during shipping. Locate the tether and remove it from its plastic bag.
2. The tether has two (2) tension adjuster hooks (one located on each end of the tether) and two (2) "free-floating" tether hooks. See Figure 5.

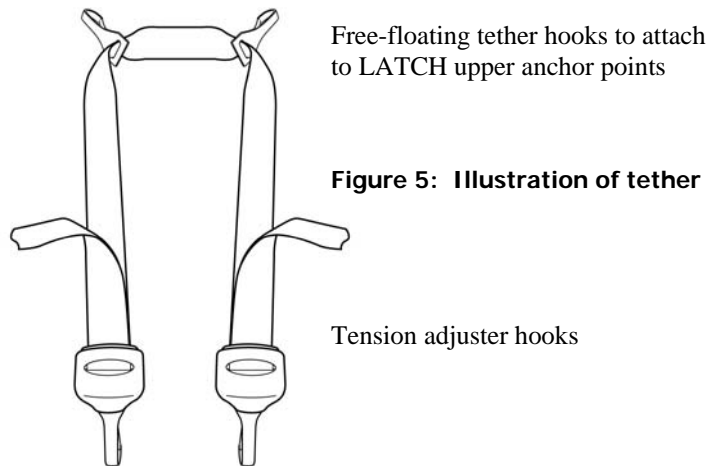

Figure 5: Illustration of tether

- necessary to use a bolt-in anchor mounting bracket. See **Installation Without LATCH Top Tether Anchors**.
12. **DO NOT USE** this restraint without the tether strap properly installed.
 13. Verify that the vehicle seat belt is tight and that the Positioning Restraint System is secure. When properly installed, the restraint will not move more than one inch (1") from side to side and or front to back. If the restraint is not secure, repeat steps 5 – 11.

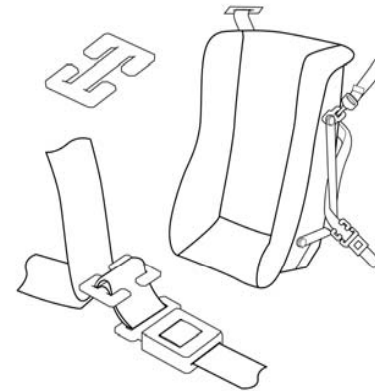

Figure 3: Combination Lap/Shoulder Belt with Locking Clip



Lap Belt Only

1. Place the Positioning Restraint System in a forward facing position on the vehicle seat. **If the front edge of the restraint extends more than one inch (1") beyond the front edge of the seat, then the vehicle seat is too shallow to properly support the restraint system. If this is the case, do not install.**
 2. Attach the tension adjuster hooks of the tether to the upper anchor points located on the sides of the Positioning Restraint System. See **Installing the Tether Strap**.
 3. Attach the tether loosely to an approved anchor point in the vehicle. In cars built after 2002, approved anchor points can be identified by this symbol. Refer to your vehicle owner's manual if needed.
- Check the seat belt in the vehicle to verify that it can be used



with the Positioning Restraint System. See **Vehicle Seat Belt Compatibility**. This restraint cannot be used with lap belts with an emergency locking retractor (ELR), which means that the lap belt will only lock in the event of a sudden stop or crash.

4. Pull the lap belt out completely, then route the belt between the back of the restraint and the metal tubes which are located along the sides of the Positioning Restraint System.
5. Make sure that the seat belt is not twisted, then buckle in place.
6. Make sure the restraint system is flat against the vehicle seat's bottom and back. Use your hands to apply firm pressure to the restraint, pushing it into the vehicle backrest—or better yet, place your knee on the restraint and push down with all your weight—while pulling on the vehicle seat belt and removing all slack from it.
7. Check to make sure the tether strap is not twisted and then tighten to secure the upper portion of the restraint. If the vehicle does not have a top tether anchor point, it will be necessary to use a bolt-in anchor mounting bracket. See **Installation Without LATCH Top Tether Anchors**.
8. **DO NOT USE** this restraint without the tether strap properly installed.
9. Verify that the vehicle seat belt is tight and that the Positioning Restraint System is secure. When properly installed, the restraint will not move more than one inch (1") from side to side and or front to back. If the restraint is not secure, repeat steps 4 — 7.

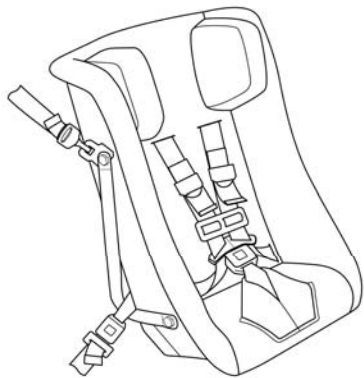

Figure 4: Lap Belt Only

Installing the Tether Strap LATCH Vehicle Installation

The TheraPedic Positioning Restraint System includes a top anchorage strap, known as a tether. The tether is engineered to make attachment to the upper anchor points of the LATCH system easier.

LATCH (**L**ower **A**nchor and **T**ethers for **C**hildren) anchors have been required on all US passenger vehicles since 2002.

IMPORTANT: Read these instructions completely and check your vehicle owner's manual prior to installation to determine the proper attachment method and locations to position this Positioning Restraint System.

Important Safety Warnings:

The tether must be used when installing the Positioning Restraint System. Use of the tether improves safety and reduces the risk of injury.



- The tether must only be attached to tether anchor points designated as tether anchor points by the vehicle manufacturer. This icon is used by vehicle manufacturers to identify the LATCH anchors. Use of other locations is not approved or permitted.

